



StarryNight

Cool Moisture Humidifier

USE AND CARE MANUAL



- ♥ Self-regulating evaporative system
- ♥ Filters impurities from the water
- ♥ Multiple output settings

IMPORTANT!
READ AND SAVE THESE INSTRUCTIONS

V3700
Series

IMPORTANT SAFETY INSTRUCTIONS

⚠️ READ AND SAVE THESE IMPORTANT SAFETY INSTRUCTIONS BEFORE USING THIS HUMIDIFIER

WHEN USING ELECTRICAL APPLIANCES, BASIC PRECAUTIONS SHOULD ALWAYS BE FOLLOWED TO REDUCE THE RISK OF FIRE, ELECTRICAL SHOCK AND INJURY TO PERSONS, INCLUDING THE FOLLOWING:

1. The humidifier should always be placed on a firm, flat, waterproof surface at least 1.2 metres away from bedside, 15 centimetres from the wall and out of reach of patients, children and pets. Be sure the humidifier is in a stable position and the power cord is away from heated surfaces and out of the way to prevent the humidifier from being tipped over.
2. This humidifier is not intended for use by persons (including children) with reduced physical, sensory or mental capabilities, or lack of experience and knowledge, unless they have been given supervision or instruction concerning use of the humidifier by a person responsible for their safety. Children should be supervised to ensure that they do not play with the humidifier.
3. The humidifier should not be left unattended in a closed room since air could become saturated and leave condensation on walls and furniture. Leave room door partly open. **DO NOT** aim mist vent directly at children, walls or furniture.
4. Before using the humidifier, extend the cord and inspect for any signs of damage. **DO NOT** use the unit if the cord has been damaged. If the supply cord is damaged, it must be replaced by the manufacturer, its service agent or similarly qualified persons in order to avoid a hazard.
5. To avoid fire or shock hazard, plug the humidifier directly into a 240V AC electrical outlet.
6. The humidifier should always be unplugged and emptied when not in operation or while being cleaned. Shut off and unplug humidifier before moving. **DO NOT** move or tilt humidifier while it is in operation. Plug and unplug unit with dry hands. **Never** pull by cord.
7. **DO NOT** operate the humidifier without water. Turn off and unplug humidifier when tank is empty. Unplug the humidifier during filling and cleaning.
8. Caution: To avoid the risk of fire, shock or personal injury, **DO NOT** use an extension cord.
9. Humidifier requires regular cleaning. Refer to and follow cleaning instructions.
10. **DO NOT** operate outdoors; this humidifier is intended for indoor use.
11. **DO NOT** cover or insert objects into any openings on humidifier. Note: You can use Vicks VapoPads (VSP-19 Original Menthol Scent) with this product (sample included). Insert pad into scent pad slot only. **DO NOT** add any medications (e.g. VapoSteam, inhalants or essential oils with this product), doing so will damage the humidifier and void your warranty.
12. **DO NOT** attempt to repair or adjust any electrical or mechanical functions on this humidifier. Doing so will void your warranty.
13. Care should be taken when using the humidifier due to the emission of hot water vapour.
14. For residential use only.

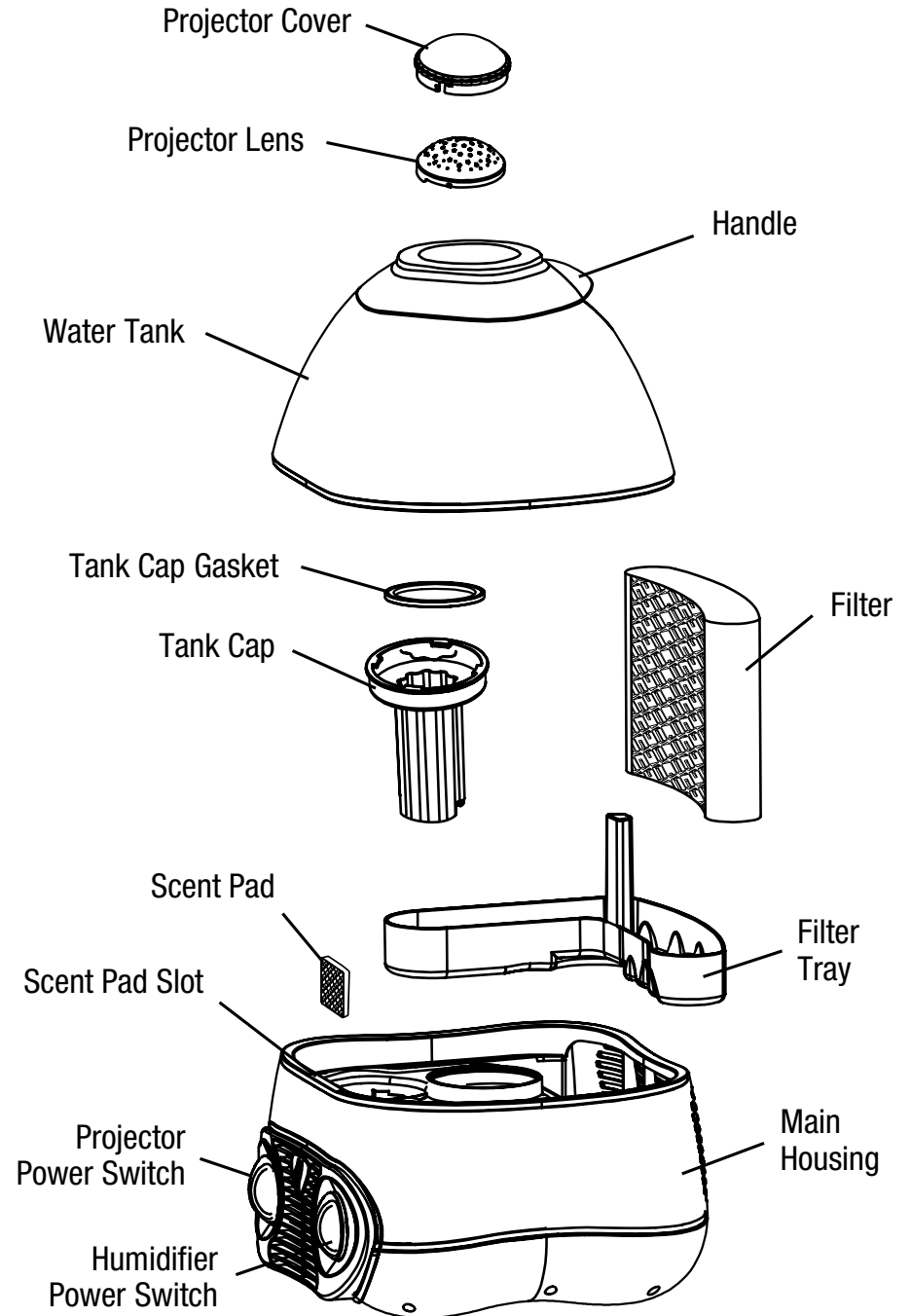

SETTING UP YOUR HUMIDIFIER

Placement

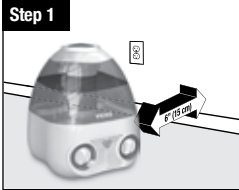

Select a firm, level location at least 6" (15cm) from any walls for proper airflow. Place the humidifier on a water-resistant surface, as water can damage furniture and some flooring.

Kaz will not accept responsibility for property damage caused by water spillage.

Soak Filter



Remove tank and set aside. Remove filter from humidifier and soak the filter in cool water.

DO NOT wring filter.



Remove filter tray from unit before installing the wet filter.



Fold filter flat. Insert wet filter into filter tray. Place filter tray back in humidifier.

Scent Pad (Optional)



Remove tank and locate Scent Pad slot.



If there is a used scent pad in the slot carefully remove it. Replace with a new scent pad. Carefully open scent pad bag taking care to hold pad using bag. Use care not to come in direct contact with new scent pad.



Insert scent pad with angled side facing downward into the scent pad slot. You can use the bag as a holder during insertion.

WARNING: DO NOT add any medications (e.g. VapoSteam, inhalants or essential oils) into Mist Outlet, Base, Water Reservoir or Water Tank. Doing so will damage the humidifier and void your warranty.

Vicks® Scent Pads work with heat to gradually release soothing aromatic vapors. One complimentary menthol vapor scent pad is included with your unit.

Recommended Usage for the Vicks® Menthol Scent Pad (VSP-19):

- Not recommended for infants under 4.5 kg.
- For children between 4.5-10 kg do not use more than 2 pads in a 24 hour period.

SETTING UP YOUR HUMIDIFIER (CONT'D.)

Scent Pad (Optional)

WARNING: DO NOT rub face or eyes after touching scent pad. **DO NOT** put fingers in mouth after touching scent pad. Oils in the pad could act as an irritant to eyes.

WARNING: As long as your humidifier is on, the scent pad heater will also be activated. This area can be warm to the touch.

INGREDIENTS: Eucalyptus Oil, Menthol, Glycol, Cedar Leaf Oil & Others

NOTE: Replace with Vicks® Scent Pads, models VSP-19

Fill Tank



Turn tank upside-down. Remove tank cap by turning counter-clockwise ↺.



Fill tank with cool tap water. Replace tank cap. Tighten by turning clockwise ↻. Place tank back on humidifier.



Once the filled water tank has been placed on the base do not move humidifier. Doing so could cause leakage and spills.

Do not use hot water when filling humidifier

OPERATING YOUR HUMIDIFIER

Power

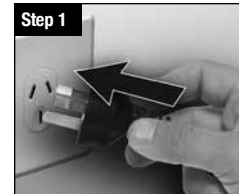

With the power switch in the OFF position, plug the filled humidifier into a polarized 240V outlet.

DO NOT plug in humidifier with wet hands to avoid electric shock.

Output



Set fan speed to desired output:

Max (↻) Max Moisture

Sleep Mode (⌘) Night time sound sleep mode

StarryNight Projector



Turn the power switch to the on position to activate the starrynight projector.

Note: Projector can be operated independently of the humidifier.

CHANGING YOUR FILTER

NOTE: It is recommended that all maintenance be done in the kitchen or bathroom on a water resistant surface. Remove water tank from unit before moving.

The filter should be changed every 1-3 months depending on your water quality. Keep in mind, depending on your water quality, mineral deposits can still clog or discolor the filter, affecting its life and that of the humidifier.

To change the filter:



Step 1
Uses replacement filter WF2.

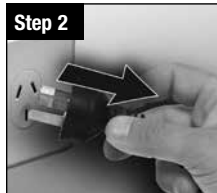

Step 2
Turn off and unplug your humidifier.



Step 3
Remove the water tank and filter tray.



Step 4
Remove filter tray from unit. Discard old filter and set filter tray aside.



Step 5
Soak new filter in cool water.



Step 6
DO NOT wring filter.



Step 7
Insert new filter into filter tray. Place filter tray back in humidifier.

NOTE: For best fit and performance remove filter tray from the humidifier and insert presoaked new filter.



Step 8
Replace the water tank.

FILTER MAINTENANCE

It is recommended you change your Wicking Filter every 30-60 days depending on water quality and usage. If you have hard water you may need to replace your filter more frequently. Change your filter if you notice:

- The filter is hard and crusty
- The filter starts to give off an odor
- Moisture output is decreased

Be sure to use only Protec™ Replacement filters. This humidifier takes Protec WF2 Replacement Filter. The filter is Protec antimicrobially treated and helps prevent the growth and migration of mold, algae and bacteria on the filter. To prolong the life of your Wicking Filter, turn it over each time you fill the Water Tank. This will keep the top of the filter from drying out and will help the filter to age more evenly.

If you notice the filter getting hard, you may soak the Wicking filter in cool water to loosen mineral buildup. This will temporarily improve the performance until a replacement filter is purchased.

DO NOT attempt to clean the Wicking Filter with vinegar or any chemical solutions. Doing so may damage the filter.

CLEANING

Cleaning involves two steps, SCALE REMOVAL and DISINFECTING. Be sure to perform these in the proper order to avoid harmful chemical interactions.

NOTE: REMOVE FILTER BEFORE CLEANING. Failure to remove filter during cleaning will destroy the filter

SCALE REMOVAL (Recommend this process be performed on a weekly basis)

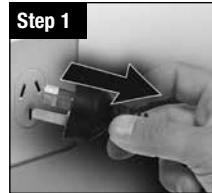

Step 1
Turn off and unplug your humidifier.



Step 2
Remove and empty water tank.



Step 3
Remove filter and set aside.



Step 4
Remove Filter Tray and fill filter tray and water tank with undiluted vinegar and soak for 10-15 minutes.



Step 5
Using undiluted vinegar wipe base thoroughly.



Step 6
Rinse water tank, filter tray and base thoroughly with water to remove scale.

DISINFECTING (Recommend this process be performed on a weekly basis)

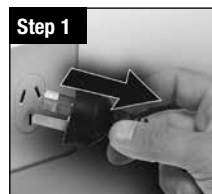

Step 1
Turn off and unplug your humidifier.



Step 2
Remove and empty water tank.

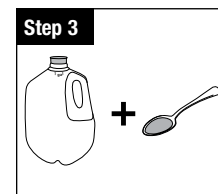

Step 3
Remove filter and set aside.

Dilute 1 tablespoon (TBS) of bleach in 3.8 litres of cool water.



Step 4
Fill water tank with water and bleach solution.

Remove water tray from unit and fill with the remaining water and bleach solution.

Wipe base with the same solution.

CLEANING (CONT'D.)

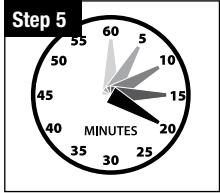

Let stand for 20 minutes.



Rinse water tray and water tank thoroughly with water until the smell of bleach is gone.

NOTES: The use of other water treatment products and chemicals may cause deterioration of the filter or damage the humidifier, thereby hindering the humidifier's effectiveness.

END-OF-SEASON CARE AND STORAGE

- Follow the CLEANING instructions when the humidifier will not be used for at least one week or more, or at the end of the season.
- At the end of the season, remove and throw away the filter; do not store with a used filter.
- Dry the humidifier completely before storing. DO NOT store with water inside the Base or Water Tank.
- Pack the unit in its original carton and store in a cool, dry location.
- Before next use, remember to clean your humidifier and install a new filter.

ELECTRICAL RATINGS

The Vicks® models are rated at 240V, 50 Hz.

NOTE: DO NOT ATTEMPT TO OPEN THE MOTOR HOUSING YOURSELF. DOING SO WILL VOID YOUR WARRANTY AND CAUSE DAMAGE TO THE HUMIDIFIER OR PERSONAL INJURY.

TROUBLESHOOTING

- Q: I hear the fan turning, but I don't see any mist. Is my humidifier operating properly?**
- A:** Dry air is pulled through the system and a fan disperses invisible, moisture balanced air. There is no "mist" emitted. When operating normally you will feel only cool air coming from the unit. Monitor the water level in your Tank/ Base. If you notice a decrease in the Water Tank over 24 hours then the unit is operating normally.
- Q: My unit has been running for several hours. I hear the fan spinning, but I do not notice the water level in the tank decreasing.**
- A:** First, check the filter to ensure it is wet. If the pad appears dry, remove it from the Base and gently rinse under cool water. Reposition wet filter in the Base. You may also want to note the current moisture level in your home. If the humidity level is over 60% the unit will not put out much moisture as your air is already saturated.
- Q: My filter has turned light brown and rust colored. Do I need a new filter?**
- A:** Probably not. Since your filter has been made with Protec™ antimicrobial the change in color indicates only a mineral deposit. Soak filter in a sink full of cool water to help break up deposits. The discoloration may remain but will not affect the humidifier's performance.
- Q: My humidifier doesn't appear to be as clean as when I first purchased and/or I'm smelling an unpleasant odor. What should I do?**
- A:** If you have been using your humidifier regularly for over 30 days, follow the cleaning instructions.
- Q: How do I know if it's time to replace my filter?**
- A:** The top of the filter is not moist to the touch, the filter has large holes or tears.
- Q: I recently bought my humidifier and it is operating properly. The fan is running and the water level in the tank is decreasing but the room still feels very dry.**
- A:** If you have just started using your humidifier it will take a few days to return the normal moisture balance to your room. Wood furniture, flooring, carpeting and other objects in the room will absorb moisture before it can re-saturate the air. If you run this humidifier with the door open you may be humidifying a larger area than this humidifier was intended for. Try running with the doors closed. If your house does not have adequate insulation this could effect the amount of moisture your room is maintaining.

LIMITED WARRANTY

This product has been produced with the greatest care for normal, household use. Following directions carefully will ensure dependable operation. If your Vicks® Humidifier is found to be defective (other than through misuse), we will repair or replace it at no charge during the 3 year warranty period. Modification to the product by the consumer is not authorised and voids the warranty.

If you experience unsatisfactory operation, please contact Felton Grimwade & Bosisto's as per below. If repair is required under the warranty period, the product should be returned with proof of purchase to Felton Grimwade & Bosisto's service centre.

The purchaser assumes responsibility for the proper care and use of the product in accordance with the printed operating manual. The purchaser or user must make his or her judgment as to when to use the product and the length of use. Keep the operation manual available as it is your guide to safe, efficient operation.

Our goods come with guarantees that cannot be excluded under the Australian Consumer Law. You are entitled to a replacement or refund for a major failure and for compensation for any other reasonably foreseeable loss or damage. You are also entitled to have the goods repaired or replaced if the goods fail to be of acceptable quality and the failure does not amount to a major failure.

© 2019 All rights reserved.

Helen of Troy Health and Home.

This product is manufactured by KuoTong Electrical Technology (Huizhou) Co., Ltd. for Helen of Troy Health and Home under license from The Procter & Gamble Company or its affiliates.

Protec™ is a trademark of Helen of Troy Limited.

Distributed by: Felton Grimwade & Bosisto's Pty. Ltd.

61-81 Clarinda Road (Po Box 74),
Oakleigh South, Victoria 3167, Australia

Free call: 1800 655 841

E-mail: mail@fgb.com.au

Website: www.fgb.com.au

